

LOCKOUT/TAGOUT BALL VALVE



FEATURES:

- Designed to accept most OSHA approved locks/shackles.
- Available as complete valve assembly or as kit for field retrofit.
- Parts fabricated from corrosion resistant thermoplastic..

FITS MOST STANDARD
OSHA APPROVED
LOCKS / SHACKLES

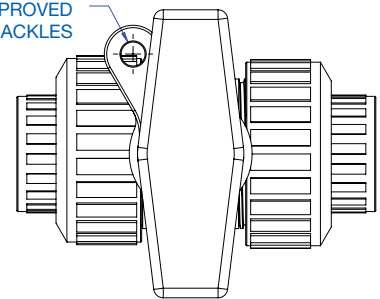

KIT NUMBER	BALL VALVE SIZE	H		H1	
		IN.	MM.	IN.	MM.
MBVL-1.2	½"	2.4	60.4	3.4	85.8
MBVL-1.6	¾" - 1"	3.2	81.0	4.4	112.3
MBVL-2.5	1¼" - 2"	4.2	107.5	6.3	159.2
MBVL-3	3"	8.3	210.0	119.	301.4
MBVL-4	4"	9.4	238.7	14.0	355.5

Part numbers shown are for field retrofit. For new valve, add -L suffix to full part number. Example: MBV100VT-PV-L.

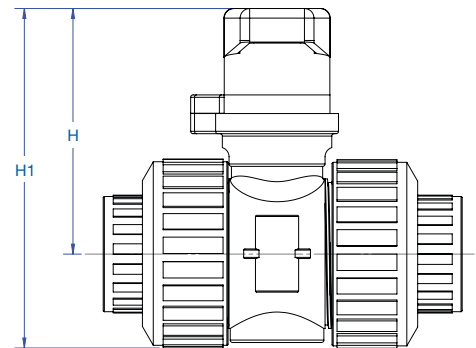

LOCKOUT / TAGOUT BALL VALVE

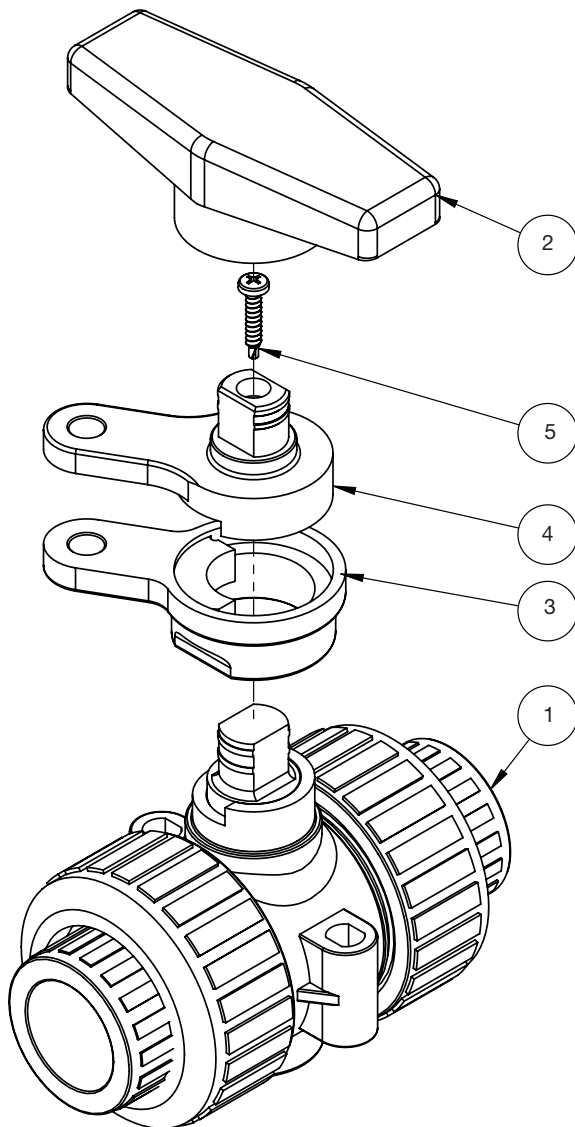

ASSEMBLY INSTRUCTIONS:

- If field retrofit, remove handle (item #2) from ball valve.
- First, with handle removed from valve, place the lower hasp (item #3) over the valve shaft and press down until it snaps onto ball valve shoulder.
- Second, align and press the upper hasp (item #4) onto the valve shaft. Screw the self-tapping fastener (item #5) through the hole on top of the upper hasp, firmly into the MBV shaft to secure the assembly.
- Finally, press the valve handle onto the upper hasp.
- The lockout assembly is now complete; turn handle to confirm smooth operation. Install OSHA approved lock to fix valve in closed position.

ITEM NO.	DESCRIPTION	QTY.
1	BALL VALVE	1
2	HANDLE	1
3	LOCKOUT, LOWER HASP	1
4	LOCKOUT, UPPER HASP	1
5	DRILLING SCREW, PAN HEAD, #6-20 X 3/4"	1